

H&S PARTS BOOK

CH4124



Revision #00
Starting Ser. #611100

Part #72823
HSMFG0416

P.O. BOX 768, MARSHFIELD, WI 54449
(715) 387-3414 FAX (715) 384-5463
www.hsmfgco.com

CONTENTS

Instructions for Ordering Parts - About Improvements	1
Figure 1 - Hitch & Components	2-3
Figure 2 - Frame Components	4-5
Figure 3 - Main Frame Slider	6-7
Figure 4 - Taddem & Hub Assembly.....	8-9
Figure 5 - Optional Tires	10-11
Figure 6 - Brake Hub Assembly (Optional)	12-13
Figure 7 - Brake Line Assembly (Optional)	14-15
Figure 8 - Brake Harness Assembly (Optional).....	16-17
Figure 9 - Scale Mount Assembly (Optional).....	18-19
Figure 10 - Scale Display Assembly (Optional)	20 -21
Parts Notes	22

INSTRUCTIONS FOR ORDERING PARTS

All service parts should be ordered through your authorized H&S dealer. They will be able to give you faster service if you will provide them with the following

1. Model & Serial number is located on the left, rear main frame of your unit.
2. All reference to left or right apply to the machine as viewed from the rear.
3. Parts should not be ordered from illustration only. Please order by complete part number.
4. If your dealer has to order parts - give shipping instructions:
VIA truck - large pieces (please specify local truck lines)
VIA United Parcel Service (include full address)

H&S MFG. CO. INC.	
MARSHFIELD, WIS.	
MOD. NO.	<input type="text"/>
SER. NO.	<input type="text"/>
DESCR.	<input type="text"/>

PLEASE RECORD NUMBERS FOR YOUR UNIT FOR QUICK REFERENCE

ABOUT IMPROVEMENTS

H&S IS CONTINUALLY STRIVING TO IMPROVE IT'S PRODUCTS

We must therefore, reserve the right to make improvements or changes whenever it becomes practical to do so without incurring any obligation to make changes or additions to the equipment previously sold.

FIGURE 1

HITCH & COMPONENTS

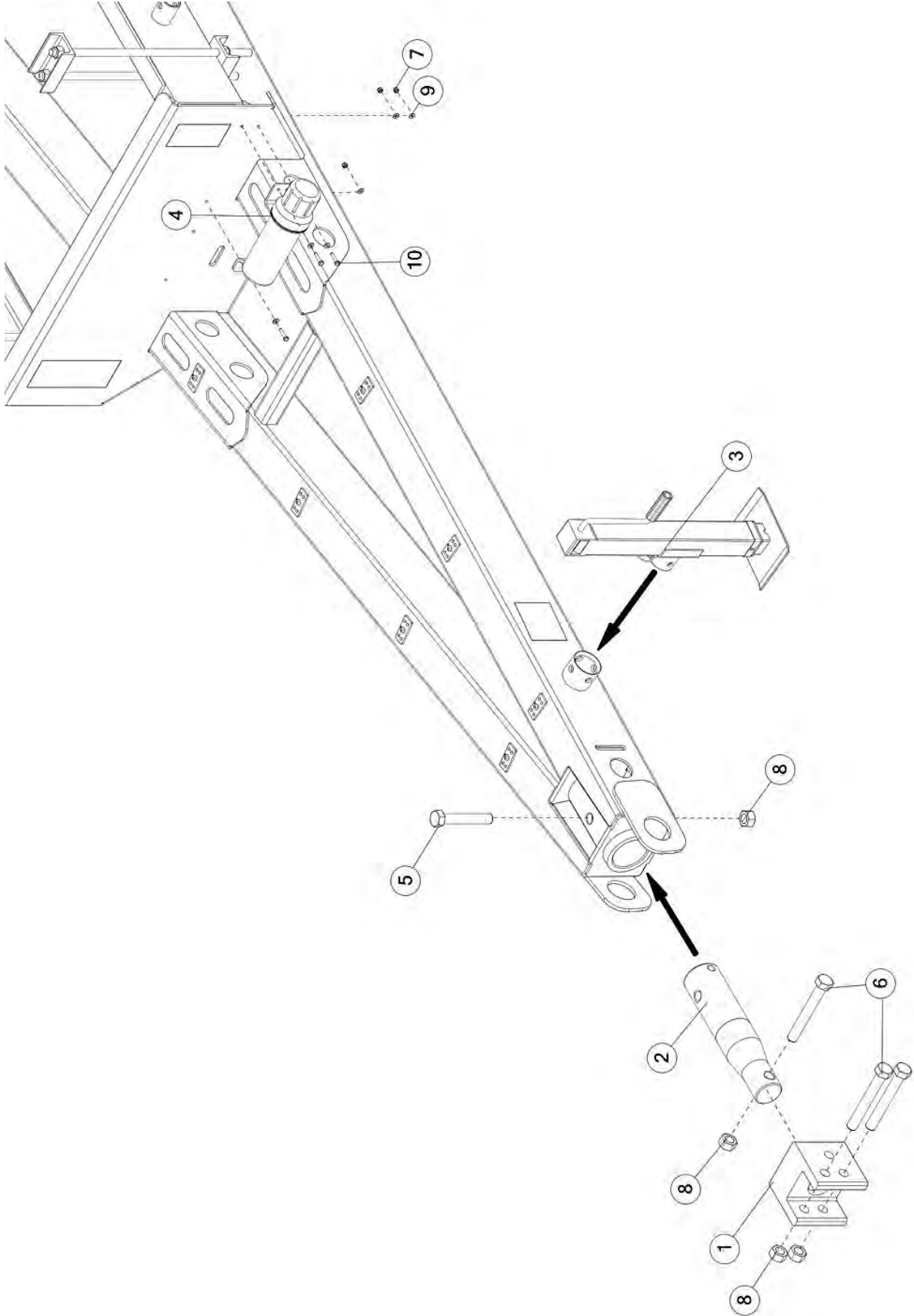

FIGURE 1

HITCH & COMPONENTS

<u>ITEM</u>	<u>QTY</u>	<u>PART #</u>	<u>DESCRIPTION</u>
F	1	APX3HF41	JAPAN HITCH ADAPTER
*	1	HTCHC	CHASSIS HITCH CLEVIS
*	1	HTCHP	CHASSIS HITCH PINTLE
*	1	HTCHB	CHASSIS HITCH BULLNOSE
2	1	TS210	HITCH BAR
3	1	TS306	7000 LB SQUARE JACK 15" TRAVEL
4	1	S522	MANUAL HOLDER
5	1	YBHH32026	BOLT, 1-8 X 6 GR. 8 (YELLOW ZINC)
6	3	YBHH32034	BOLT, 1"-8 X 7-1/2 GR. 8
7	3	YNNY08005	HEX NUT, NYLON LOCKNUT, 1/4-20
8	4	YNTL32005	HEX NUT, TOP LOCK, 1"-8 GR. C, ZINC
9	3	YWFL08010	WASHER, FLAT, 1/4" SAE GR. 8 (YELLOW ZINC)
10	3	YBHH08035	BOLT, 1/4 X 1-1/4 GR 5

NOTE: * MEANS NOT SHOWN

FIGURE 2
FRAME & COMPONENTS

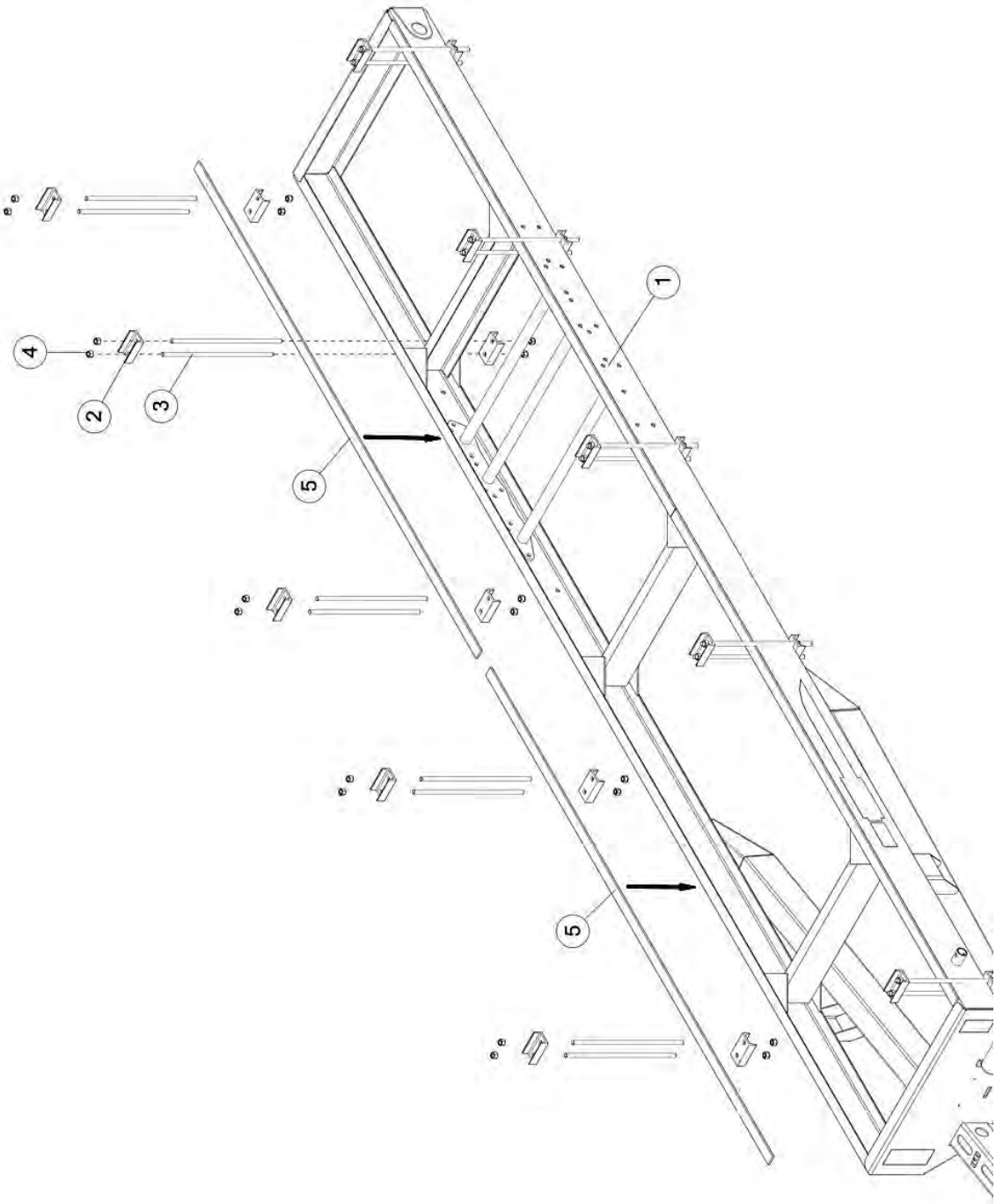

FIGURE 2

FRAME & COMPONENTS

<u>ITEM</u>	<u>QTY</u>	<u>PART #</u>	<u>DESCRIPTION</u>
1	1	72789	FRAME, WLDMT, 24 CHASSIS
2	20	70602	CHL, C, 3.00 X 1.52 X 5.25, TIE DOWN
3	20	FBC6	SCR, ROD, 0.75 - 16 X 24.0, G5, ZC
4	40	YNNY24006	HEX NUT, NYLON LOCKNUT, 3/4-16
5	4	72806	LUMBER, 123.5 X 2.00 X 0.19

FIGURE 3
MAIN FRAME SLIDER

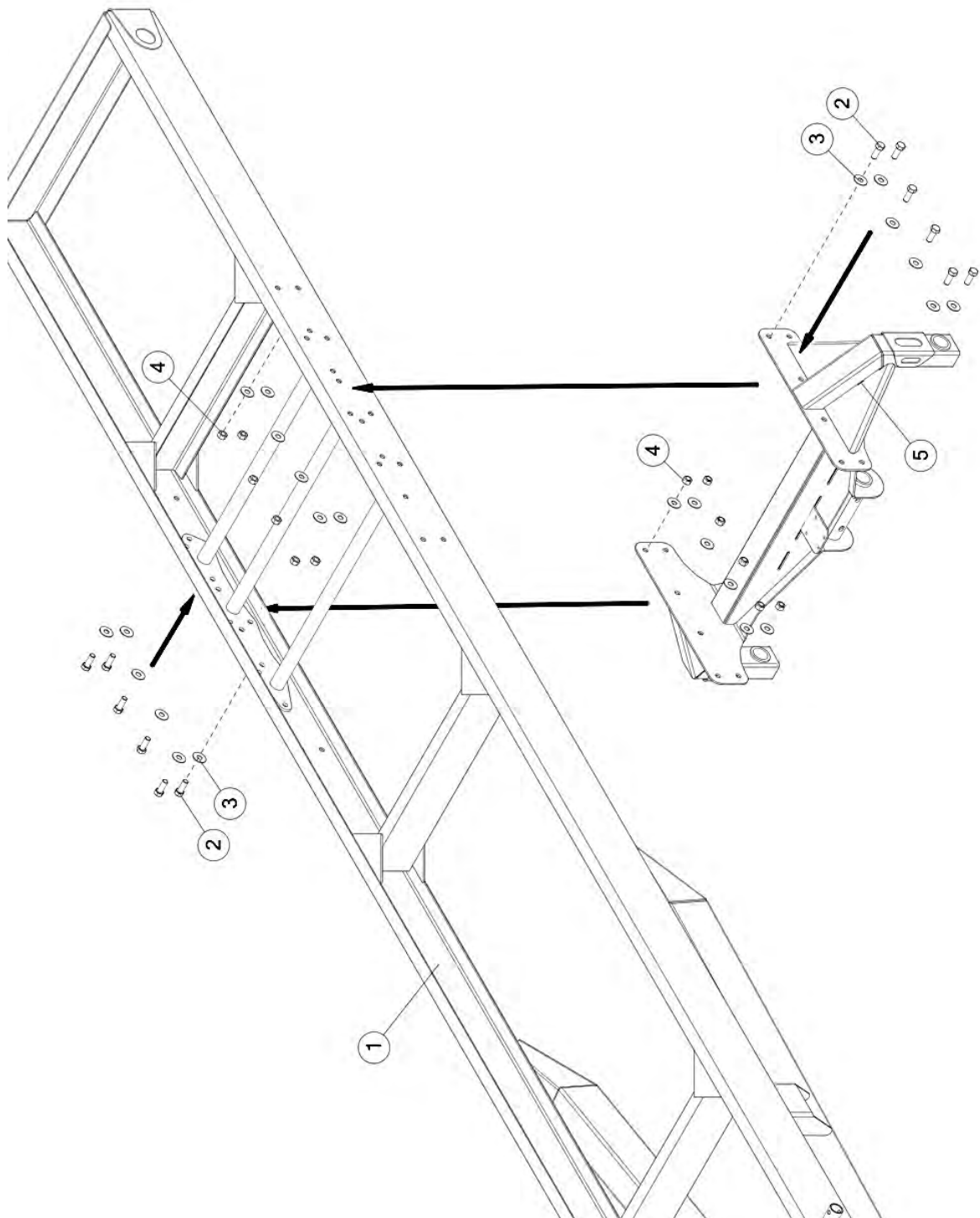

FIGURE 3
MAIN FRAME SLIDER

<u>ITEM</u>	<u>QTY</u>	<u>PART #</u>	<u>DESCRIPTION</u>
1	1	72789	FRAME, WLDMT, 24 CHASSIS
2	12	YBHH24018	BOLT 3/4-10 X 2 GR 8 Yellow Zinc
3	24	YWFL24005	WASHER, FLAT, 3/4 USS
4	12	YNL24005	HEX NUT, TOP LOCK, 3/4-10
5	1	72598	FRAME, WLDMT, SLIDER

FIGURE 4
TANDEM & HUB ASSEMBLY

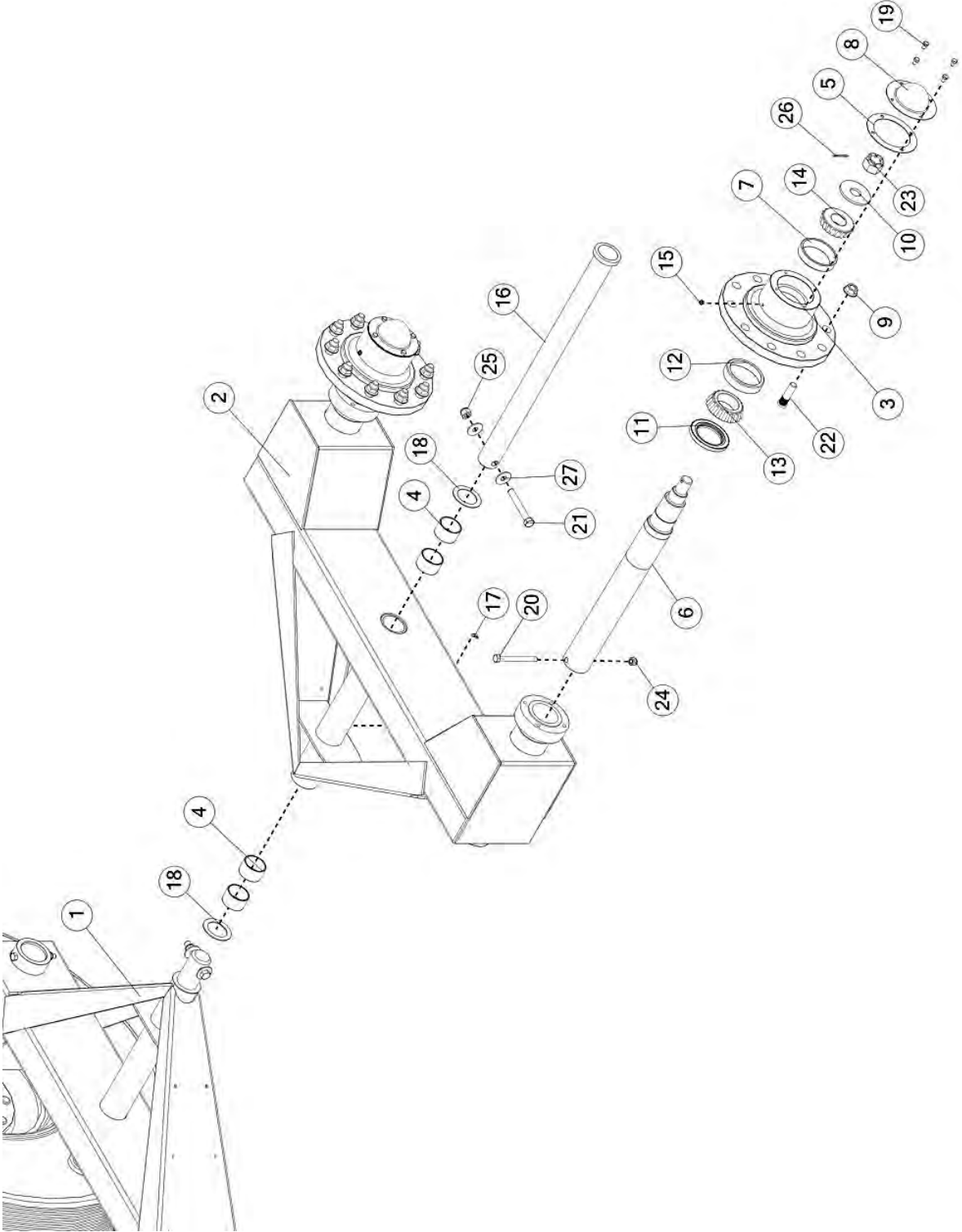

FIGURE 4

TANDEM & HUB ASSEMBLY

<u>ITEM</u>	<u>QTY</u>	<u>PART #</u>	<u>DESCRIPTION</u>
1	1	50N152	TANDEM BEAM RH
2	1	50N151	TANDEM BEAM LH
3	4	60N8	871 CAST HUB W/RACES ONLY , 10 BOLT
4	8	50N8	BUSHING, BRONZE 2.50 OD X 2.265 ID X 1.5
5	4	56234	HUB CAP GASKET
6	4	60N1	3.00" X 27.500" SPINDLE FOR 871 HUB
7	4	60N10	OUTER RACE--600 BUSHEL
8	4	60N11	HUB CAP--600 BUSHEL
9	40	60N14	HEX FLANGE NUT, 3/4-16 UNF-28, GR 8
10	4	60N2	SPINDLE WASHER
11	4	60N5	GREASE SEAL
12	4	60N6	INNER RACE--600 BUSHEL
13	4	60N7	TAPERED ROLLER BEARING, 2.495 BORE
14	4	60N9	TAPERED ROLLER BEARING, 1.75 BORE
15	4	BFR28	1/8" NPT GREASE ZERK
16	2	50N153	TANDEM PIN
17	2	RG51	ZERK, 90 DEGREE 1/4"-28
18	4	RG59	WASHER, THRUST 3.25 OD X 2.281 ID X .075
19	16	YBHH10020	BOLT, 5/16 X 1/2 GR 5
20	4	YBHH16155	BOLT, 1/2 X 5 GR 5
21	2	YBHH20070	BOLT, 5/8-11 X 4-1/2 GR 5, ZINC
22	40	YBSD24010	STUD BOLT, 3/4-16UNF X 2-3/4 (3/4 SHOULDER)
23	4	YNCA36005	HEX NUT, CASTLE, 1-1/4"-12
24	4	YNNY16005	HEX NUT, NYLON LOCKNUT, 1/2-13
25	4	YNNY20005	HEX NUT, NYLON LOCKNUT, 5/8-11
26	4	YPCT05010	COTTER PIN 5/32" X 1-1/2"
27	4	YWFL20005	WASHER, FLAT, 5/8 USS

FIGURE 5

OPTIONAL TIRES

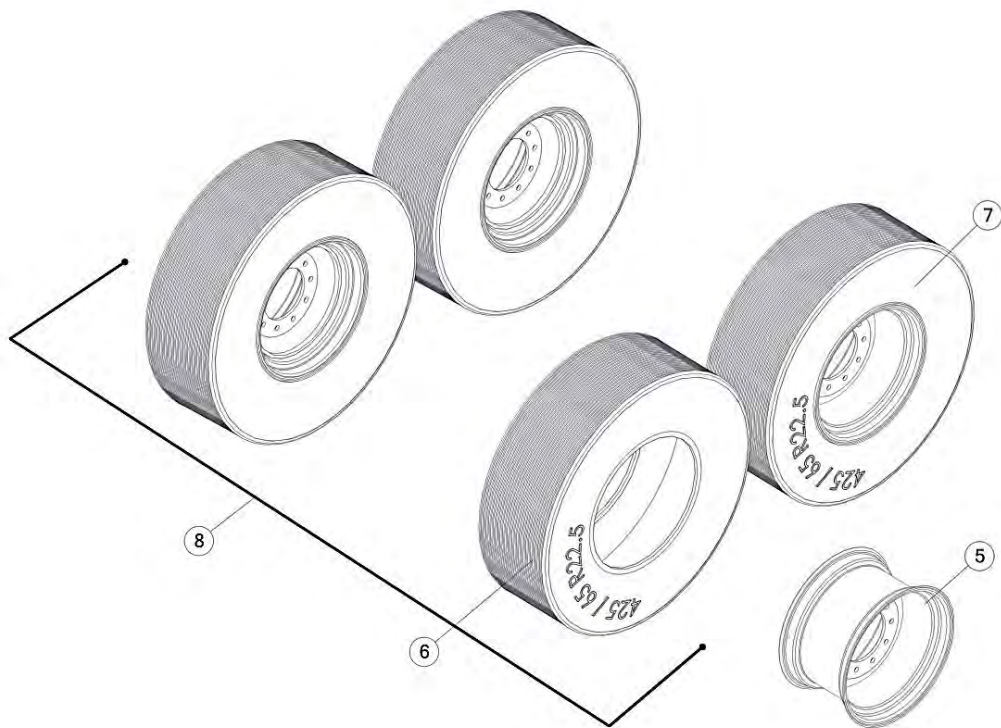
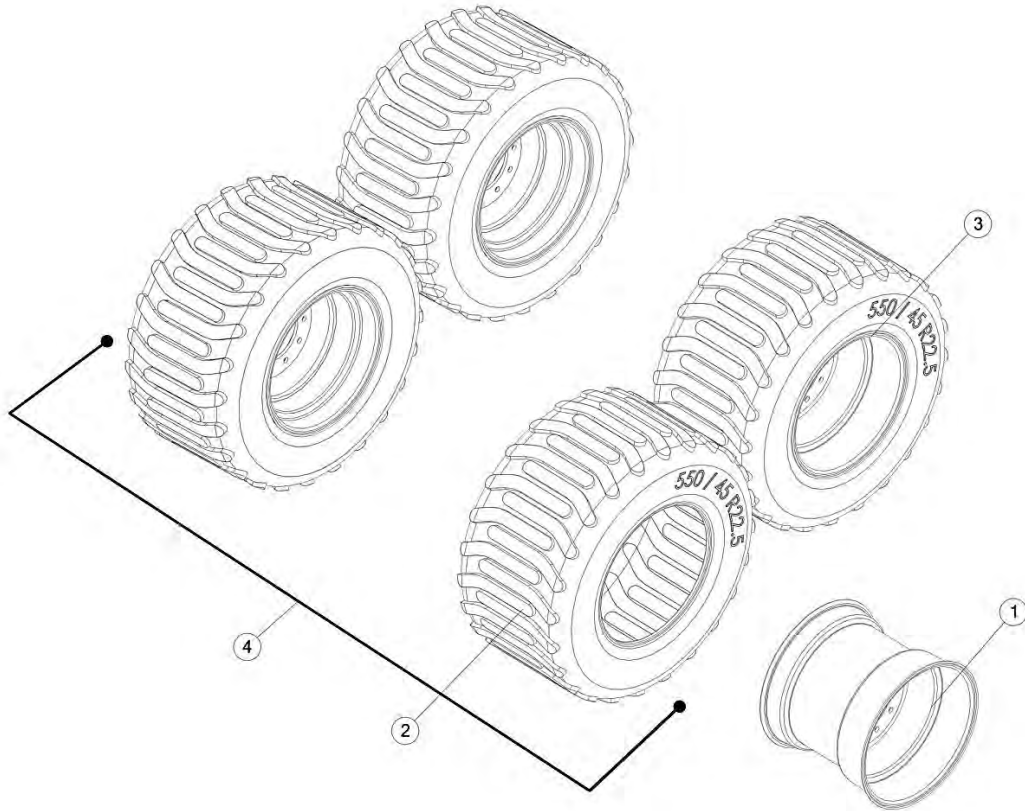

FIGURE 5

OPTIONAL TIRES

<u>ITEM</u>	<u>QTY</u>	<u>PART #</u>	<u>DESCRIPTION</u>
1	4	66777	WHEEL 22.5 X 20
2	4	33381	TIRE, 550 FLOATATION
3	4	69975	WHEEL, ASSY, 550 WHEEL AND TIRE ASSY. 550
4	4	WBOC550	FLOAT OPTION
5	4	60N15	WHEEL, 22.5 X 13.0, 10 BOLT, OFF-WHITE
6	4	16SV88	TIRE, 425-65 X 22.5
7	4	33236	425 X 22.5 TIRE ON 22.5 X 13.5, 10 BOLT WHEEL
8	4	TWP42510	ASSY, 425 TRUCK TIRE OPTION

FIGURE 6
BRAKE HUB ASSEMBLY (OPTIONAL)

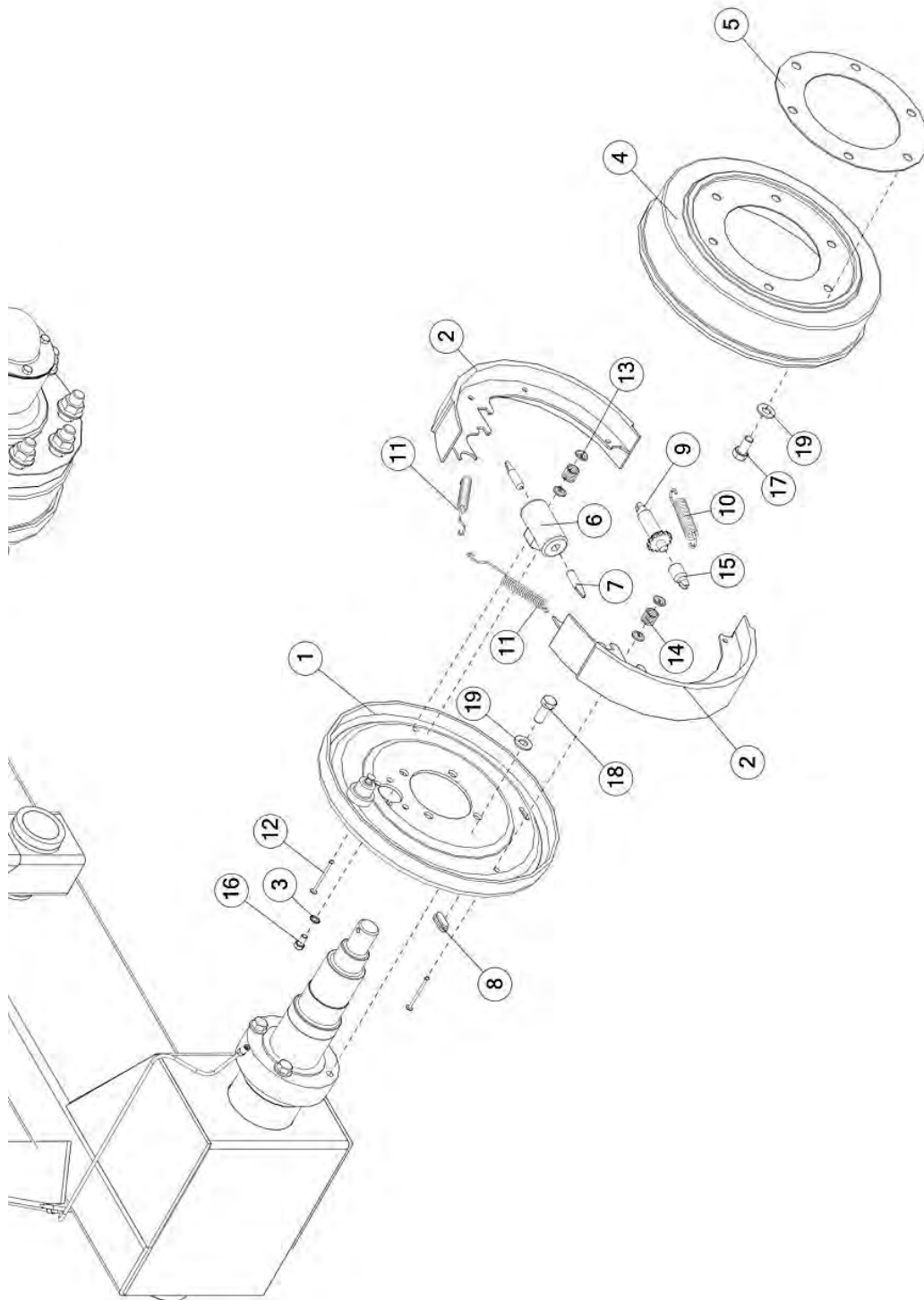

FIGURE 6
BRAKE HUB ASSEMBLY (OPTIONAL)

<u>ITEM</u>	<u>QTY</u>	<u>PART #</u>	<u>DESCRIPTION</u>
1	1	74293	13" INCH FB BRAKE
2	2	FBC50	BRAKE SHOE REAR
3	2	YWSI10005	FRONT SHOE ASSEMBLY
4	1	RGE10	13" INCH BRAKE DRUM
5	1	CB20	DRUM SPACER
6	1	74292	WHEEL CYLINDER ASSEMBLY LEFT
*	1	74291	WHEEL CYLINDER ASSEMBLY RIGHT
7	2	FBC54	PUSH ROD
8	1	FBC55	COVER PLATE ADJUSTING HOLE
9	1	74289	ADJUSTING SCREW
10	1	RGB50	SPRING ADJUSTING SCREW
11	2	RGB55	SPRING SHOE
12	2	RGB56	PIN-SHOE HOLD DOWN
13	4	RGB57	CUP SHOE HOLD DOWN
14	2	RGB59	SPRING HOLD DOWN
15	1	74290	BRAKE ADJUSTER SOCKET
16	2	YBHH10132	BOLT, 5/16"-18 X 5/8" GR. 5
17	6	YBHH16010	BOLT, 1/2"-13 X 1" GR 5
18	4	YBHH16045	BOLT, 1/2-13 X 1-1/4 GR 5
19	4	YWFL16010	WASHER, FLAT, SAE 1/2

NOTE: * MEANS NOT SHOWN

FIGURE 7 **BRAKE LINE ASSEMBLY (OPTIONAL)**

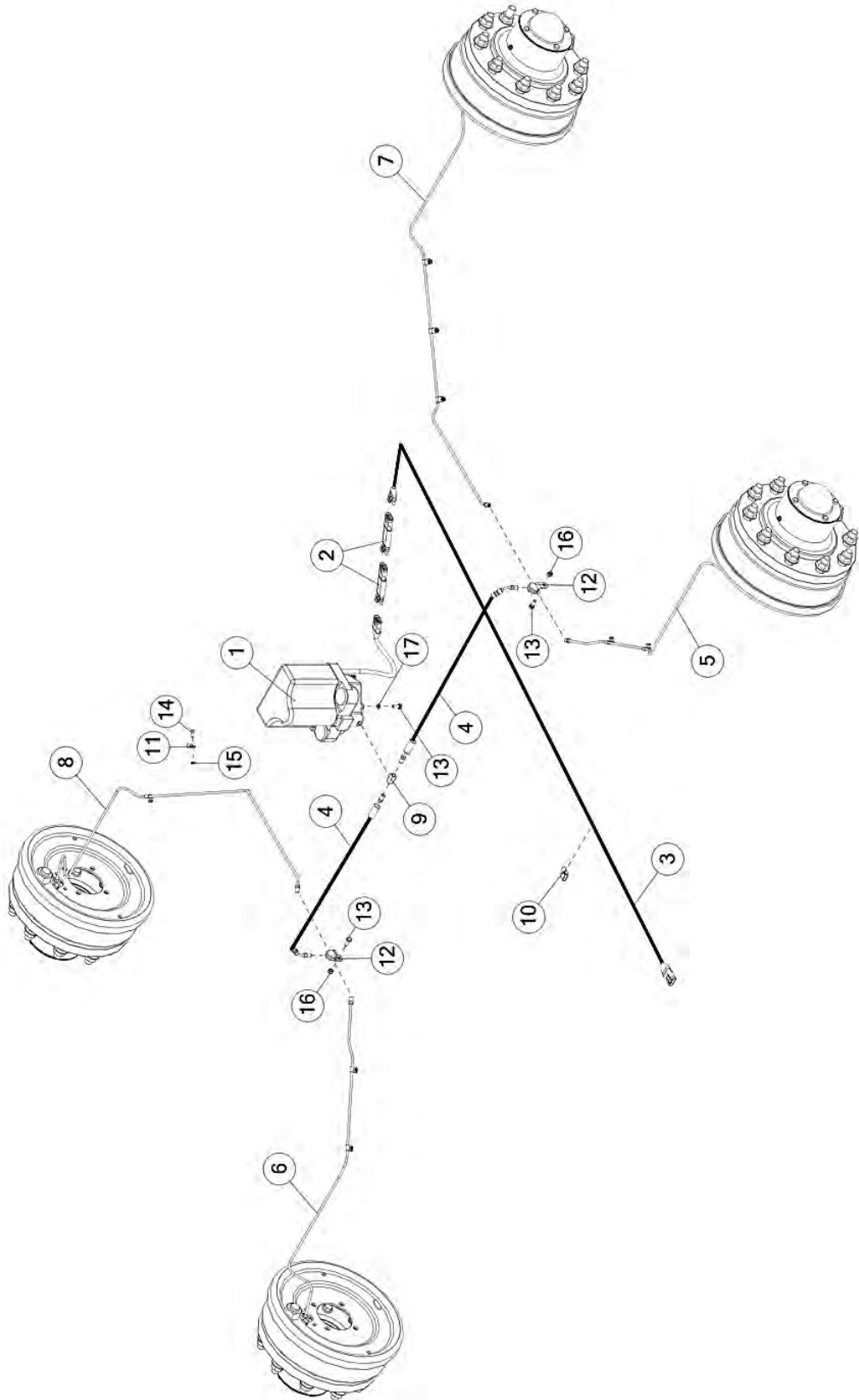

FIGURE 7

BRAKE LINE ASSEMBLY (OPTIONAL)

<u>ITEM</u>	<u>QTY</u>	<u>PART #</u>	<u>DESCRIPTION</u>
1	1	FBC41	PUMP/MASTER CYLINDER
*	1	73958	ELEC, 3 PIN FEMALE, WTHRPK
*	3	74127	SEAL, WTHRPK, 12 AWG
*	3	74119	ELEC, WTHRPK, 12 AWG
2	2	73990	ELEC, BRAKE RESISTOR
*	2	73960	ELEC, 3 PIN MALE, WTHRPK
*	6	74123	PIN, WTHRPK, 12 AWG
*	12	74127	SEAL, WTHRPK, 12 AWG
*	6	74119	ELEC, WTHRPK, 12 AWG
*	2	73958	ELEC, 3 PIN FEMALE, WTHRPK
3	1	FBC40	PUMP/MASTER CYLINDER HARNESS
*	1	73958	ELEC, 3 PIN FEMALE, WTHRPK
*	6	74127	SEAL, WTHRPK, 12 AWG
*	3	74119	ELEC, WTHRPK, 12 AWG
*	1	73960	ELEC, 3 PIN MALE, WTHRPK
*	3	74123	PIN, WTHRPK, 12 AWG
4	2	74090	HOSE ASSY, 3/16 FLARE, 13.5
5	1	74091	ASSY, 3/16 BRAKE LINE, CHASSIS
6	1	74094	ASSY, 3/16 BRAKE LINE, CHASSIS
7	1	74095	ASSY, 3/16 BRAKE LINE, CHASSIS
8	1	74100	ASSY, 3/16 BRAKE LINE, CHASSIS
9	1	FBC45	BRANCH TEE
10	10	56021	METAL CHASSIS CLIP
11	10	74093	BRAKE, CLAMP, 1/4 X 0.50
12	2	RGB26	BRAKE LINE TEE
13	6	YBHH08100	BOLT, 1/4-20 X 3/4 GR 5
14	10	YSHS64005	SOCKET HEAD CAP SCREW, #10-24 X 1/2
15	10	YNNY64005	10-24, HEX NYLON INSERT LOCKNUT
16	2	YNNY08005	HEX NUT, NYLON LOCKNUT, 1/4-20
17	4	YWLO08005	WASHER, LOCK, 1/4

NOTE: * MEANS NOT SHOWN

FIGURE 8
BRAKE HARNESS ASSEMBLY (OPTIONAL)



FIGURE 8

BRAKE HARNESS ASSEMBLY (OPTIONAL)

<u>ITEM</u>	<u>QTY</u>	<u>PART #</u>	<u>DESCRIPTION</u>
1	1	FBC38	IN CAB CONTROLLER
*	1	74269	PLUG TOWER HALF
*	4	74123	PIN, WTHRPK, 12 AWG
*	4	74127	SEAL, WTHRPK, 12 AWG
2	1	FBC30	ELECTRIC BRAKE HARNESS
*	1	56845	7 POLE, ROUND PIN TRACTOR PLUG
*	4	74108	RECEPTACLE SHROUD HALF
*	3	74118	ELEC, WTHRPK, 14/16 AWG
*	4	74119	ELEC, WTHRPK, 12 AWG
*	7	74127	SEAL, WTHRPK, 12 AWG
*	1	73961	ELEC, 4 PIN BOX PLUG
*	1	73960	ELEC, 3 PIN MALE, WTHRPK
*	2	8753	SPADE TERMINAL TAB
3	1	FBC39	BRAKE CONTROL MODULE
*	1	73958	ELEC, 3 PIN FEMALE, WTHRPK
*	3	74123	PIN, WTHRPK, 12 AWG
*	3	74127	SEAL, WTHRPK, 12 AWG
4	2	56564	CLAMP TOP PLATE
5	2	56569	CLAMP BOLT
6	2	56596	CLAMP CUSHION (SET OF 2)
7	2	YBHH08035	BOLT, 1/4-20 X 1-1/4 GR 5
5	2	YNNY08005	HEX NUT, NYLON LOCKNUT, 1/4-20
9	4	YWFL08010	WASHER, FLAT, 1/4" SAE GR. 8 (YELLOW ZINC)

NOTE: * MEANS NOT SHOWN

FIGURE 9 SCALE MOUNT ASSEMBLY (OPTIONAL)

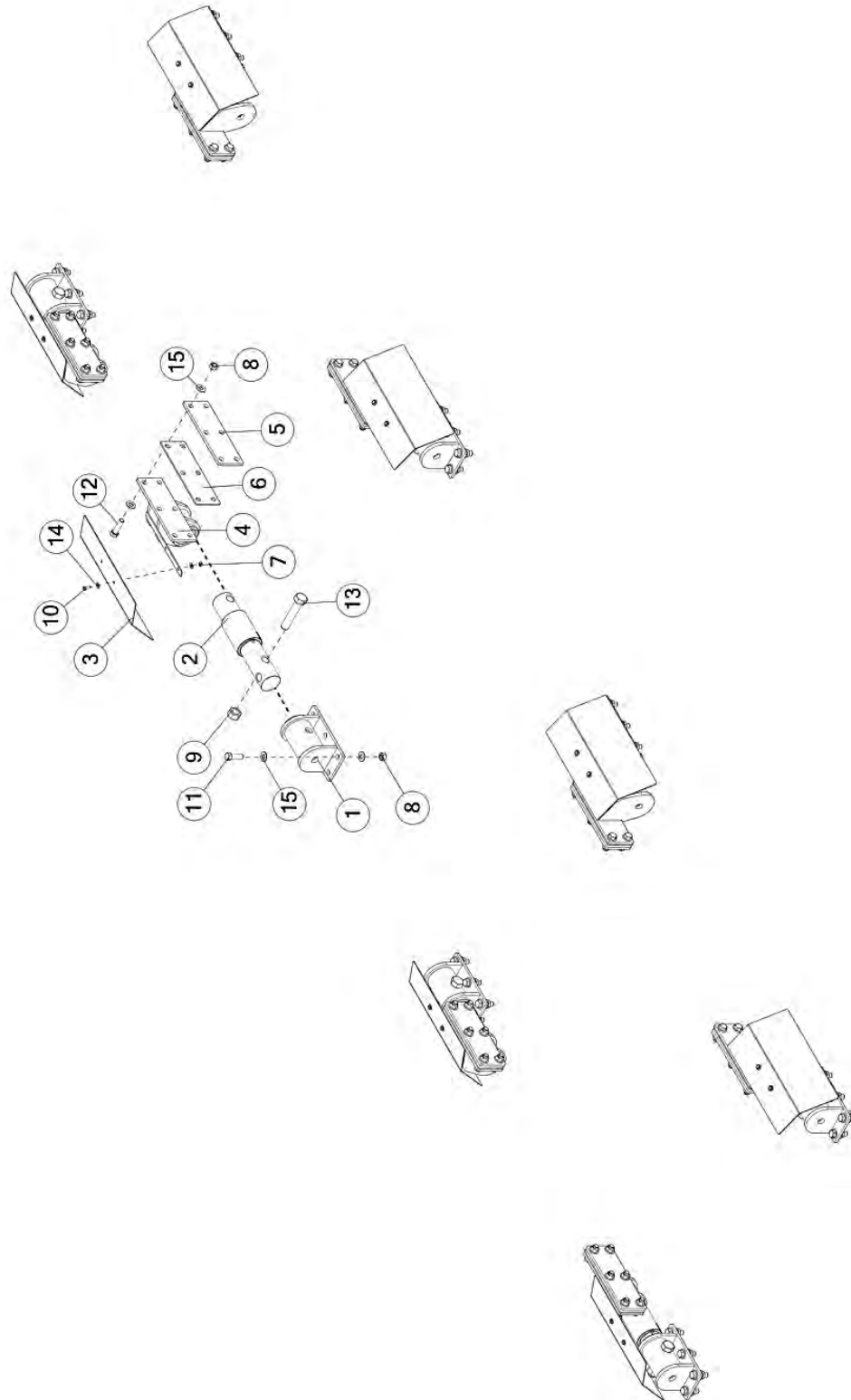

FIGURE 9
SCALE MOUNT ASSEMBLY (OPTIONAL)

<u>ITEM</u>	<u>QTY</u>	<u>PART #</u>	<u>DESCRIPTION</u>
1	8	59466	FRAME CELL MOUNT
2	8	59496	CELL-2.875 DB-21
3	8	59473	SHIELD, LOAD CELL
4	4	59485	COMPONENT CELL MOUNT-CHECK
*	4	59467	COMPONENT CELL MOUNT
5	8	74304	PLT, 12.0 X 4.00 X 0.38
6	8	74305	PLT, 12.0 X 4.00 X 0.12, SHIM
7	16	YNNY08005	HEX NUT, NYLON LOCKNUT, 1/4-20
8	96	YNTL20005	HEX NUT, TOP LOCK, 5/8-11
9	8	YNTL32005	HEX NUT, TOP LOCK, 1"-8 GR. C, ZINC BOLT,
10	16	YBHH08100	1/4-20 X 3/4 GR 5
11	48	YBHH20025	BOLT, 5/8-11 X 2 GR 5
12	48	YBHH20040	BOLT, 5/8 X 2-1/4 GR 8
13	16	YBHH32023	BOLT, 1 X 5 GR 8
14	32	YWFL08005	WASHER, FLAT, 1/4 USS
15	192	YWFL20010	WASHER, FLAT, 5/8" SAE GR 8 YELLOW ZINC

NOTE: * MEANS NOT SHOWN

FIGURE 10
SCALE DISPLAY ASSEMBLY (OPTIONAL)

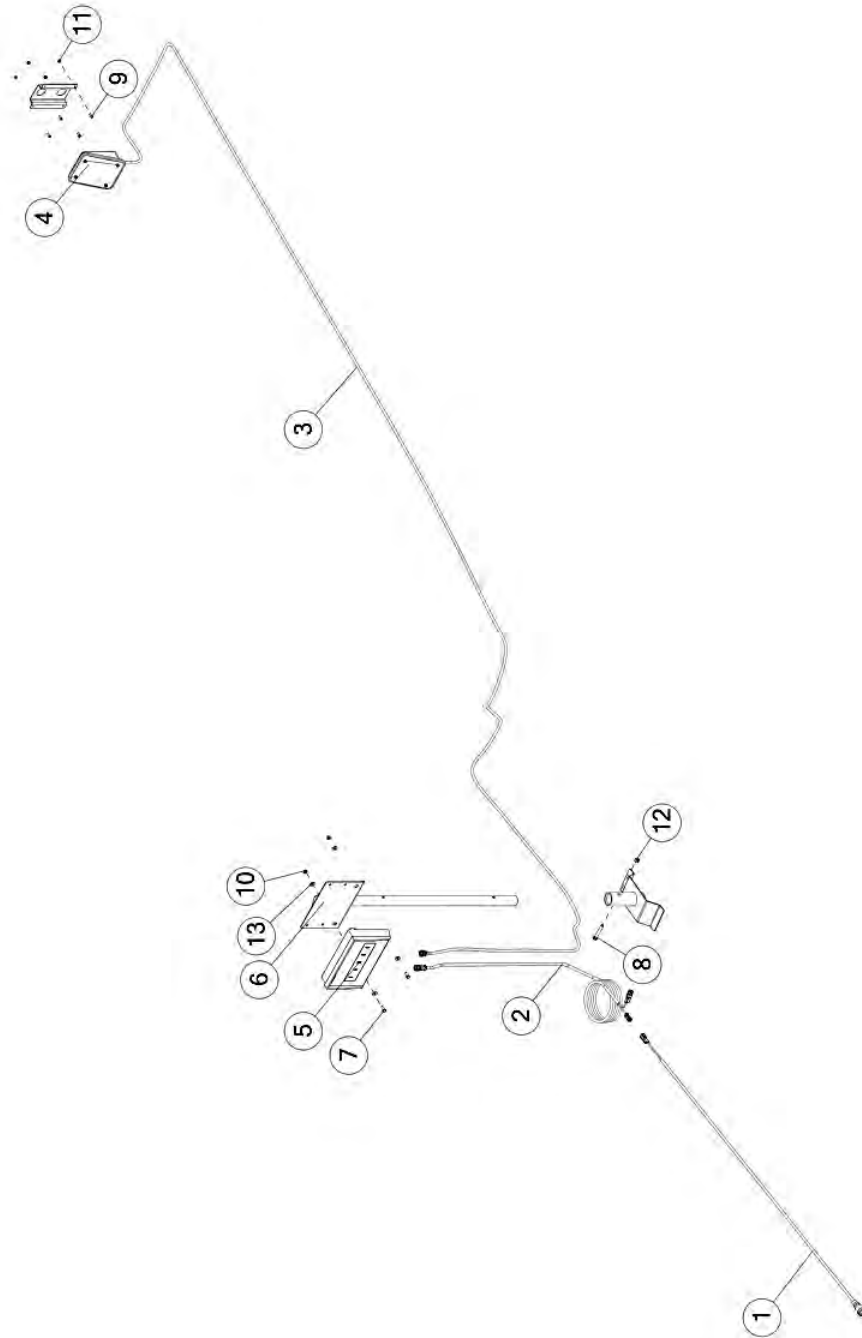
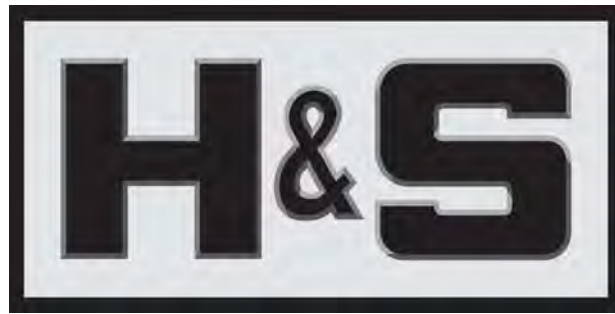

FIGURE 10
SCALE DISPLAY ASSEMBLY (OPTIONAL)

<u>ITEM</u>	<u>QTY</u>	<u>PART #</u>	<u>DESCRIPTION</u>
1	1	59107	CABLE, POWER
2	1	71872	HARN, ELEC, SCALE, 10'
*	1	58793	LOCKING WEDGE FOR DT06-2S CONNECTOR
*	1	58790	DEUTSCH 2 PIN PLUG HOUSING
*	4	56861	DEUTSCH 2 PIN RECEPTACLE HOUSING
*	2	56863	LOCKING WEDGE FOR DT04-2P CONNECTOR
*	1	56760	DEUTSCH SOCKET, SOLID, 14-16 GA.
*	2	SE215	DEUTSCH PIN, SOLID, 14-16 GA.
3	1	74018	ELEC, HARNESS, J BOX 275.0
4	1	71914	ASSY, J-BOX 6-8 CELL MODULE
5	1	GM404	NV2500 INDICATOR STD
6	1	71889	WLDMT, POLE, INDICATOR MOUNT
7	2	YBHH08100	BOLT, HEX, 1/4-20 X 3/4, G5, ZC
8	1	YBHH12090	BOLT, 3/8-16 X 2-1/2 GR 5
9	4	YSHS64005	SOCKET HEAD CAP SCREW, #10-24 X 1/2
10	2	YNNY08005	HEX NUT, NYLON LOCKNUT, 1/4-20
11	4	YNNY64005	10-24, HEX NYLON INSERT LOCKNUT
12	1	YNTL12005	HEX NUT, TOP LOCK, 3/8-16
13	4	YWFL08005	WASHER, FLAT, 1/4 USS

NOTE: * MEANS NOT SHOWN



**H&S Manufacturing products are approved for the
FEMA SEAL OF QUALITY**

**P.O. BOX 768, MARSHFIELD, WI 54449
(715) 387-3414 FAX (715) 384-5463
www.hsmfgco.com**